



# Thai Metal Product Industry Co.,Ltd.

47/8, 47/10 Moo 1, Rat Niyom Sub-District, Sai Noi District, Nonthaburi 11150 Thailand.

Tel : 0 2985 5544, 08 6303 9169 Fax : 0 2985 5995

www.thaimetal.co.th E-mail : thaimetal@gmail.com



ISO 9001 : 2015

## AIR RECEIVER

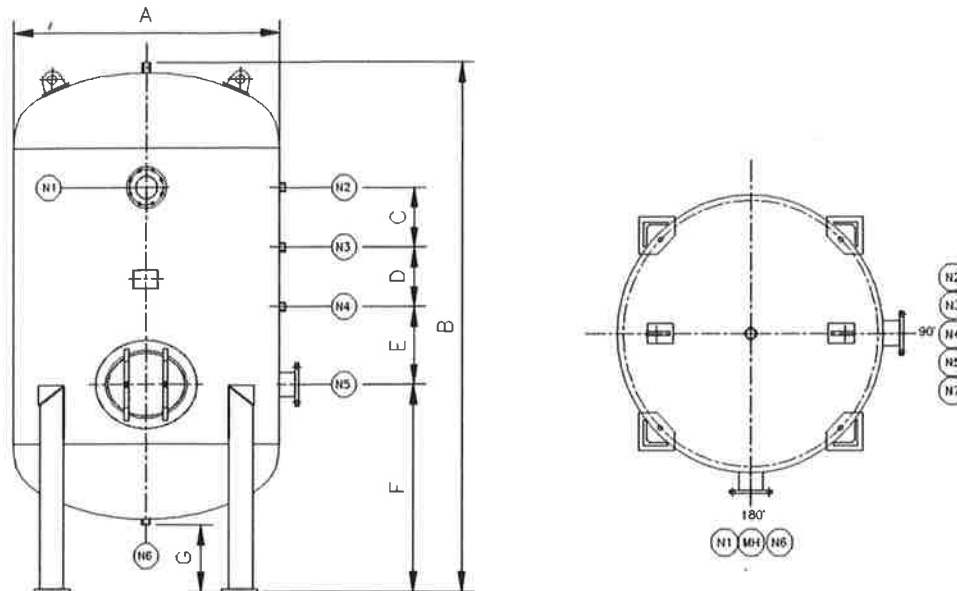

NOZZLE DETAIL	AIR RECEIVER (LITER)								
	T-1000	T-1500	T-2000	T-2500	T-3000	T-4000	T-5000	T-6000	
N1 OUTLET NOZZLE	2"	2"	2"	2"	3"	4"	4"	5"	
N2 SAFRTY VALVE	1"	1"	1"	1"	1"	1"	1"	1"	
N3 PRUSSER GUAGE	1/2"	1/2"	1/2"	1/2"	1/2"	1/2"	1/2"	1"	
N4 AIR REGULATER	1"	1"	1"	1"	1"	1"	1"	1"	
N5 INLET NOZZLE	2"	2"	2"	2"	3"	4"	4"	5"	
N6 DRAIN	3/4"	3/4"	3/4"	3/4"	1"	1"	1"	1"	
N7 HYDRO TEST	1"	1"	1"	1"	1"	1"	1"	1"	
MH MANHOLE	11" x 15"	11" x 15"	11" x 15"	11" x 15"	11" X 15"	11" x 15"	11" x 15"	11" x 15"	
MATERIAL	SS400								
WORKING PRESSURE [BAR/ PSI.]	10/150								
HYDROSTATIC TEST [BAR/ PSI.]	15/225								
APPROX. WEIGHT [KG.]	262	330	540	617	690	857	1107	1271	
COATING	<input type="checkbox"/> ALKYD COATING NON ALKYD PRIMER  ALKYD TOPCOAT				<input type="checkbox"/> EPOXY COATING SA 2.5 / COALTAR EPOXY SA 2.5 / ZINE RICH EPOXY EPOXY UNDERCOAT POLYURETHANE				
INTERIA									
EXTERIA PRIMER									
INTERMEDIATE									
FINISHING									
DIMENSTION [MM.]	A	940	1040	1290	1290	1400	1400	1740	1740
	B	2150	2400	2340	2640	2690	3290	2870	3270
	C	201	196	197	197	305	905	304	704
	D	200	400	200	500	400	400	400	400
	E	300	300	300	300	300	300	300	300
	F	939	964	1033	1033	1055	1055	1147	1147
	G	328	328	326	326	320	320	323	323
	Thickness	6	6	8	8	8	8	9	9
	LEG	3	3	4	4	4	4	4	4